

T 800 Truck



Advanced touch-screen wheel balancer for truck wheels





TOUCHSCREEN

Large **22" touch-screen monitor** with intuitive graphical user interface, for simplifying and speeding up program selection and balancing operations.



AUTOSEL EVO

Intelligent system for measuring distance and wheel diameter **up to 30"**, equipped with the AUTOSEL Evo and the new LaserBlade pointer. AUTOSEL Evo automatically activates balancing programs, while the **LaserBlade** pointer improves accuracy and visibility when identifying the inner planes of the rim, for an optimized balancing process.



NEXT-GENERATION SPIN AND MEASURING SYSTEM

Low-speed balancing cycle to reduce spin times, minimise any risks related to moving parts and save energy. It is suitable for all wheel types of heavy-duty, light, off-road and car vehicles, **ensuring precision and reliability.**

WIDE WEIGHT TRAY AND MULTIFUNCTION BUTTON

Rotational weight tray with multiple compartments to efficiently organise counterweights and tools.

The tray features a **multifunction button to facilitate the quick selection** of work programs, improving the **efficiency of operations.**





DPA AND ELECTROMAGNETIC BRAKE

The **DPA** function automatically sets the wheel in the correct balancing position at the end of the spin cycle, eliminating intermediate stops.

The **electromagnetic brake** simplifies the cleaning and application of the counterweights, making the mounting and demounting of the wheel **more efficient and less tiring**.

APPLICATION OF ADHESIVE COUNTERWEIGHTS

Adhesive counterweights can be applied in three different ways, depending on your preference:

- Ergonomically at **5 o'clock** using the new Laser Line Pro pointer.
- Manually at **6 o'clock**.
- Manually at **12 o'clock**, following the traditional method.

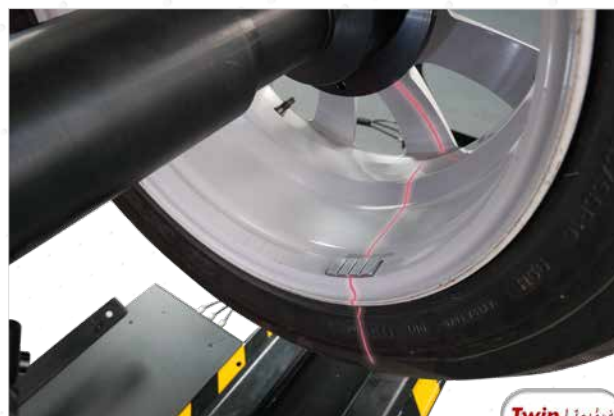

SMD AUTOMATIC SENSOR (Optional)

The Sonar Measurement Detector **SMD** automatically measures the wheel width without contact. No manual entry by the operator is required.



INTEGRATED LED ILLUMINATOR

The **LED illuminator** improves visibility of the work area to **facilitate rim cleaning** and the **application of counterweights**.



SPACE SAVING WHEEL GUARD

designed to allow the positioning along the wall, it also permits to hold wheels up to **52"** (1.321 mm) maximum diameter

INCLINED FRONT PART

to improve operator access to the inside of the rim



INTEGRATED WHEEL LIFTING SYSTEM

Integrated low-profile pneumatic lifting system, manually operated without pedals. It easily lifts **wheels of up to 300 kg**, ensuring perfect centring. **Ergonomic, robust and fast.**

CONTROL WEIGHT EVO

Special collection of useful programs that optimise the positioning of balancing counterweights, guaranteeing accurate results with less material usage and improving service efficiency. The ideal solution for a **faster**, cheaper and **more sustainable balancing service**.



ADVANCED DIAGNOSIS

The T 800 Truck wheel balancer, when equipped with **optional SONAR sensors**, can also be used as an **advanced diagnostic tool**. With its three diagnostic programs, it is able to identify and even resolve geometric wheel defects, eliminating vibrations that cannot be corrected in traditional balancing.

WHEEL ECCENTRICITY & BEST FIT

The Radial Runout Sensor-Wheel (**RRS-W**) automatically detects the radial eccentricity of the wheel. The **BESTFIT software** uses this data to display the point of greatest deviation on the screen, thus facilitating optimal positioning on the vehicle hub.

The Lateral Runout Sensor-Wheel (**LRS-W**) measures the lateral eccentricity of the tyre to ensure perfect alignment.



FAST MATCHING

The **FAST MATCHING** function automatically calculates the **optimal match-mounting between rim and tyre**, improving vibration reduction, increasing safety and prolonging tyre life.

The **RRS-W** and **RRS-R** diagnostic kits are required to activate this function.



RRS-W

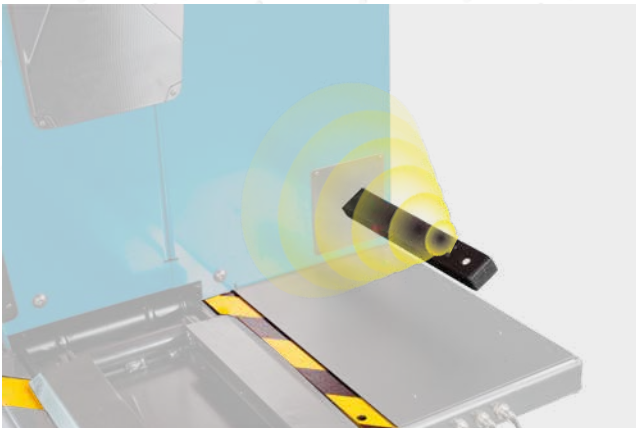

RRS-R



SPECIAL FUNCTIONS AND PROGRAMS

Wide range of programs for an easy and immediate use of the machine, including:

- **7 balancing programs** for alloy rims for truck and car wheels, Dynamic, Static, Hidden weight
- **2 working environments**
- **Multi-operator**
- **Imbalance optimisation** (Opt Flash)
- **AWC**
- **Software update** via USB.



STANDARD EQUIPMENT

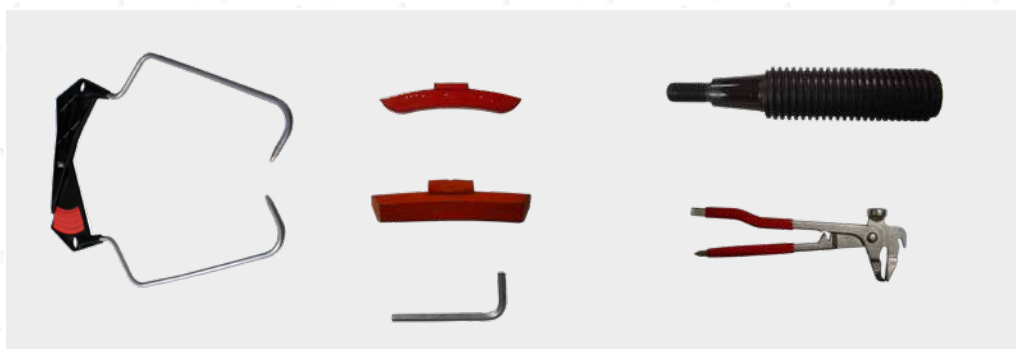

RECOMMENDED ACCESSORIES



8-21100275_GTR40 EVO
Premium steel quick nut \varnothing 40x4 mm (for MO).



8-21100269_ART40 EVO
Premium Heavy-Duty adaptor Kit (10-8-6 hole).



8-21100268_KCT40 EVO
Heavy-Duty cone Kit.

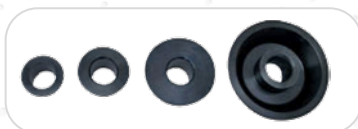

8-21900191_ARU40
Kit for car wheels with central hole \varnothing 42÷156 mm (1,65"÷6,14")



8-21100141_DX_CBF
DX/CBF Centring accessory for van and off-road wheels with central hole with \varnothing 117÷173 mm



8-21100270_ARV40
Premium Medium&Light adaptor kit for commercial vehicle (6-hole).



8-21101402_ACCESSORY RACK
Handy accessory holder support.



8-21100293/90_SMD
SMD width sensor

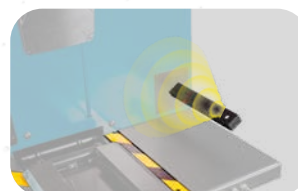

8-21100300/90_RRS-W
Radial Runout Sonar Wheel for the measurement of the tire's radial eccentricity



8-21100301_RRS-R
Radial Runout Sonar Rim for measuring the wheel rim's radial eccentricity

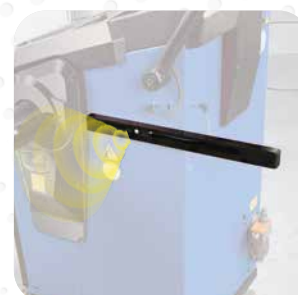

8-21100302_LRS-W
Lateral Runout Sonar Wheel for measuring the lateral eccentricity of the tire sidewall.

DIMENSIONS

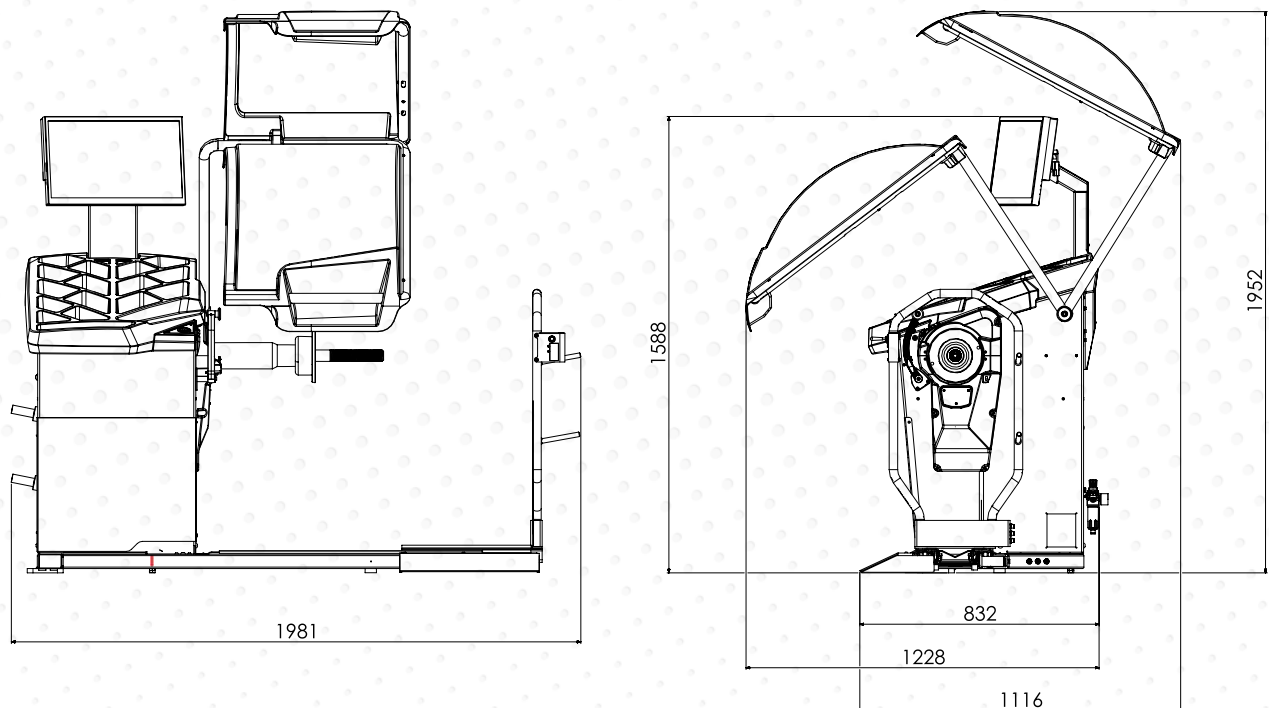

TECHNICAL DATA

Power supply	200 ÷ 230V / 1Ph / 50 ÷ 60Hz - 100 ÷ 115V / 1Ph / 50 ÷ 60Hz
Total power absorption	400 W
Balancing speed	100 rpm car / 80 rpm truck
Shaft diameter	40 mm (1,57")
Supply pressure	8 ÷ 12 bar (120 ÷ 165 psi)
Average measurement time	8 ÷ 16 s
Balancing precision	1 g car / 10 g truck
Settable rim width	1,5" ÷ 20" / 40 ÷ 510 mm
Settable rim diameter	10" ÷ 30" / 265 ÷ 765 mm
Maximum wheel weight (8 bar)	300 kg (660 lb)
Maximum wheel diameter	52" / 1321 mm
Machine weight	260 kg (573 lb)

DPSF000673 03/2025